



MOUSETRAP CAR COMPETITION

GUIDELINES FOR 2003 SECME ENGINEERING DESIGN COMPETITION (MOUSETRAP CAR: CONSTRUCTION AND OPERATION)

ENGINEERING DESIGN COMPETITION REQUIREMENTS:

(Any entry not meeting the following requirements will be disqualified.)

1. The Engineering Design Competition **requires participation in the following areas:**
 - a. Mousetrap Car, construction and run
 - b. Design Drawing of Mousetrap Car
 - c. Technical Report on Mousetrap Car
2. This is a **team competition** and should reflect the coordinated efforts of all members.
3. **Three (3) students must be on each team.** Members must remain the same at all levels of competition (school, state/regional site, and national finals).
4. Each team member is expected to be able to serve as a spokesperson and be fully involved with all aspects of the entry.
5. **A standard mousetrap**—usually about 4.5 X 10 centimeters and weighing about 25 grams—**must be used to build the car.**
6. Components of the mousetrap are: base (on which other components are mounted), spring, bail, locking lever, and bait hook (see component sketch on next page).
7. The mousetrap spring must be the sole source of power. **(You may NOT use rubber bands, CO₂ boosters, or any other agent or element for extra power).**
8. **In design and construction of the car, the original mousetrap spring and wood base MUST remain intact.** These two components may **NOT** be cut or altered in any way—physically, chemically, or thermally. Only the locking lever and bait holder may be removed from the base, if desired. **The bail may be reconfigured but NOT CUT or LENGTHENED. It must remain as a component of the completed car.**
9. The spring must be visible and/or accessible to the judges for inspection.
10. The car must have a minimum of three wheels and can be made as long or short as desired as long as requirement #8 above is met.
11. Cars will be tested on a smooth flat surface. **Distance is measured from the starting line to the farthest point of travel, utilizing a straight line to connect the two points.**
12. **There will be two runs for each car; the better run will be used for final scoring of the mousetrap car's performance.**

13. Two formulas are used to calculate the Performance score for the car run:

$$N = \left(\frac{w}{W} \right) X \left(\frac{D}{L} \right)^2 \quad \text{and} \quad F = \frac{N}{N_L} X 100$$

where:

N.... is the score.

To ensure that cars actually perform and not just be small and light,

N=0 if D is LESS than 300 centimeters (for middle school teams)

N=0 if D is LESS than 600 centimeters (for high school teams)

w.... is the mass of the mousetrap in grams (25 grams). NOTE: At ALL competitions, 25 grams will be used as the mass for the mousetrap car run calculations.

W.... is the total mass of the completed car in grams

D.... is distance measured in a straight line from the starting point to the stopping point in centimeters.

D=2,500 if the car travels 2,500 centimeters or more.

L.... is the longest dimension in any direction--**length, width, height**--in centimeters, measured with the bail extended or retracted, whichever is greater.*

N_L.... is the highest Performance score at the competition site

F.... is the final Performance score (to be combined with scores for Design Drawing and Technical Report)

*** Judges will make this measurement prior to the performance runs.**

14. Overall Team Score in competition is sum of: 1) Performance (car run) as calculated above (max. 100 points); 2) Design Drawing (max. 50 points); 3) Technical Report (max. 50 points). **Thus, the maximum total is 200 points.**

(Note: refer to sketch on page 27-28 for guidelines #13-14)

Component Sketch of Original Mousetrap

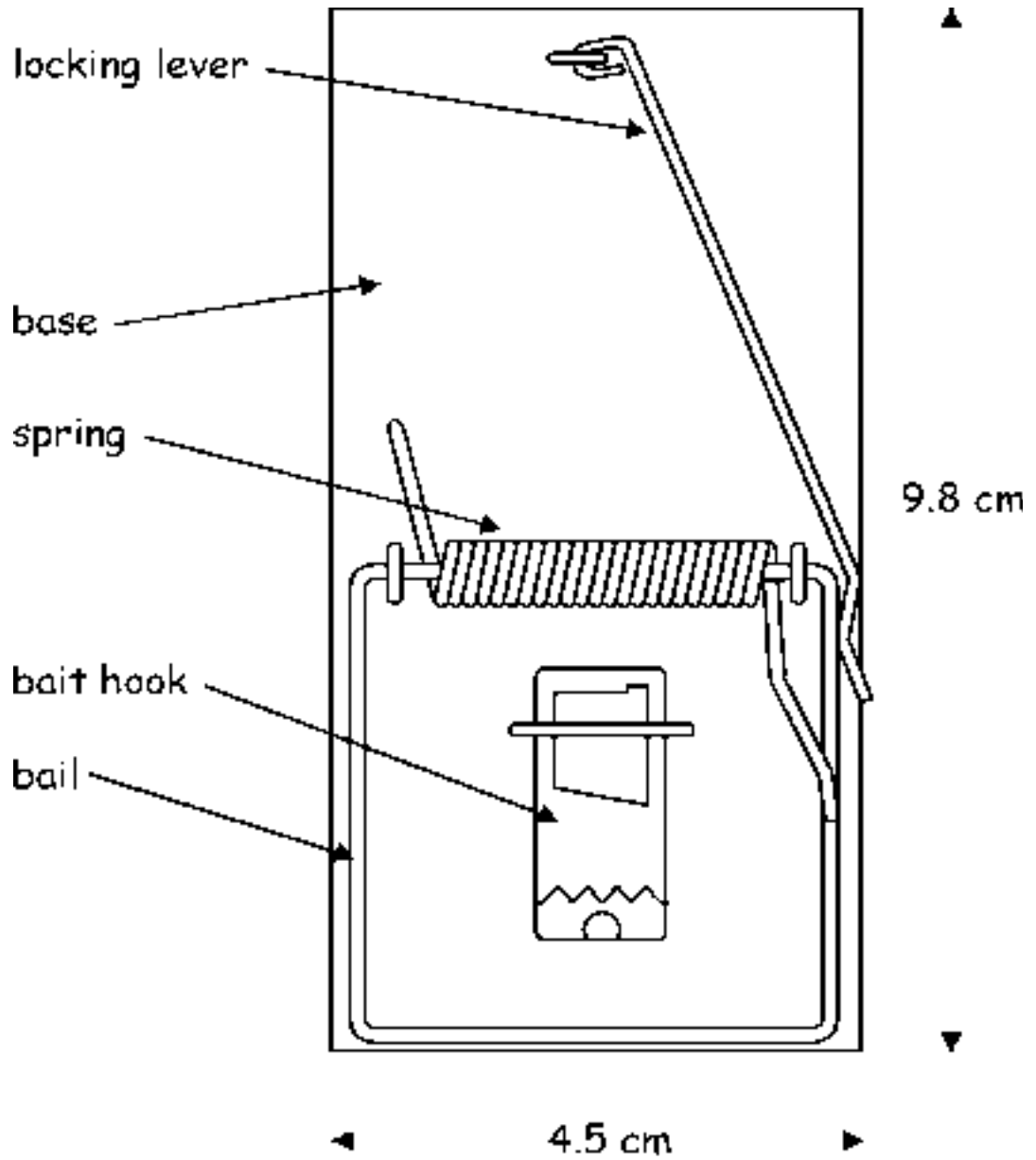
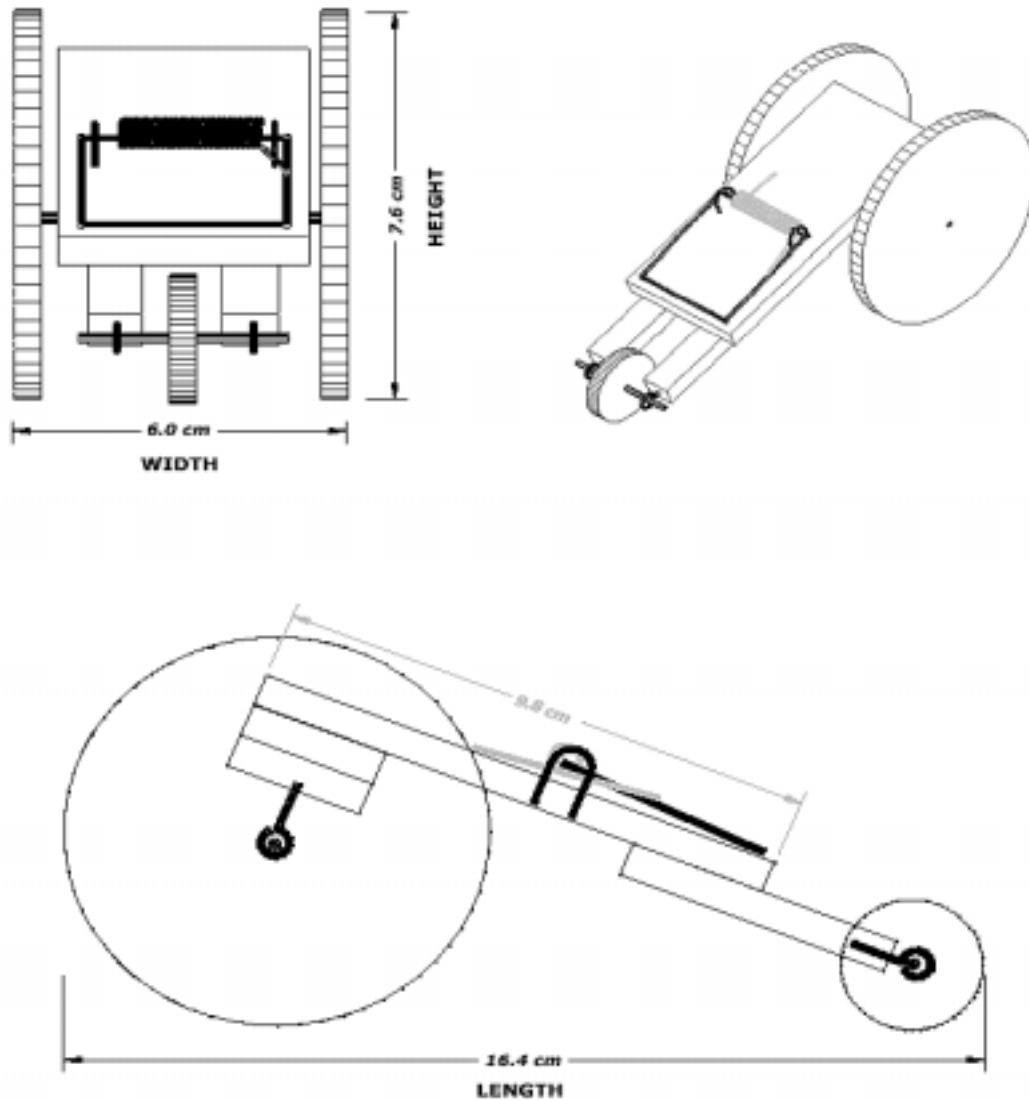

Illustration of Measured Length, Width, and Height To Determine Mousetrap Car's Longest Dimension, "L"



The longest dimension of the mousetrap car in the above drawing is its LENGTH. Thus the value for L that will be used in calculating car performance is the LENGTH or 16.4 cm.

$$L = 16.4 \text{ cm}$$



MOUSETRAP CAR COMPETITION DESIGN DRAWING RULES

As a part of the design competition, the team is required to prepare a scaled drawing depicting the car they have designed and built.

1. The Mousetrap Car Drawing entry must illustrate the actual mousetrap car built by the team (*photographs or computer-generated drawings will NOT be allowed*).
2. The size of the engineering paper is required to be the standard 18" X 24" (Allowing for the 1" margin, the actual drawing is to cover an exposed area of 16" X 22" of the paper...*No mounting, no frames allowed*).
3. All dimensions must be illustrated on the drawing.
4. The scale and the units are required to be indicated on the drawing.
5. The team's Mousetrap Car Drawing is required to show a **frontal, side, and rear view**.
6. All parts of the car are required to be labeled.
7. Ink pens, pencils, or markers may be used.
8. A 4" X 6" title card with the following information is required:

Team Name

School Name and Address

Team Members' Names, Addresses, and Grade Levels

School Coordinator's Name

Date of Competition

At all competitions, the mousetrap car drawing will be judged on the basis of:

Resemblance (between the actual mousetrap car and drawing)

Scale

Naming/Labeling (of all the parts used)

Appearance/neatness

MOUSETRAP CAR COMPETITION WRITTEN TECHNICAL REPORT RULES

1. As a part of the Design Competition, the team is required to write a Technical Report describing the design, construction, and operation of the mousetrap car. The Technical Report should be a computer-printed/typed document on 8 1/2" X 11" white paper with **one-inch borders** at the top, bottom, and on each side.
2. Use **12 pt. type** in a standard legible text font.
3. The main body of the report--**4. Introduction, 5. Design Construction, 6. Construction Procedure, and 7. Operation of the Mousetrap Car**--should be a maximum of 5 pages total.
4. Drawings, sketches, and tables may be included in an appendix, if desired, but this is optional and not required.

TECHNICAL REPORT REQUIREMENTS AND GUIDELINES:

1. Cover page (required to contain):	Title of the Technical Report a. Names, addresses, and grades of team members b. Team's school name and address c. School system name d. School Coordinator's name e. Date
2. Abstract	One-half to one-page summary of the technical report
3. Table of Contents	One page
4. Introduction	
5. Design Construction	
6. Construction Procedure	
7. Operation of the Mousetrap Car	
8. Conclusion/Recommendations	
9. Acknowledgments (optional)	
10. Appendix	<i>May contain sketches, tables, and charts.</i>

Maximum five (5) pages

